

Overview

- *Universal Fixed Wall Mount for 22-32" plasma / LCD screens and a load capacity of up to 60kg*
- *Quick and easy installation*
- *Solid steel construction, powder coated*
- *Security screw holds the screen in exact position*
- *Back plate has several holes for mounting on brick, concrete and stud walls*
- *Fits VESA standards 75x75, 100x100, 200x100, 200x200 or 400x200mm*
- *Packaging includes screws and spacers for different TV makes and models*
- *After mounting screen hangs like a picture on the wall*
- *Distance to the wall is reduced to a minimum*
- *10 years warranty*

Optional Adapters

- **SAL1**
- **CM1**
- **TR1 / TR2 / TR3**
- **SFP1**

FOR HOME & OFFICE

LWB1

Universal Fixed Wall Mount for 22-32" plasma / LCD screens

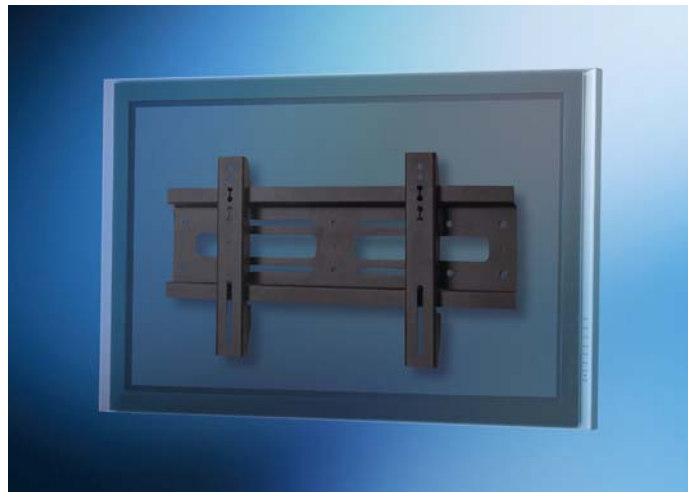

LWB1 is an universal fixed wall mount for 22-32" plasma / LCD screens with a load capacity of up to 60kg. Its design ensures quick, easy and safe installation*:

LWB1 consists of a back plate that can be fixed to a brick, stud or concrete wall and the two front plates that are mounted to the back of the screen.

The screen together with the front plates can be comfortably hooked to the back plate. The universal bracket contains also two security screws in order to keep the screen in position.

Included in the box are screws and spacers for different TV makes and models.

*LWB1 can be fixed directly to the wall or can be used with adaptors for swing arm, trolley or ceiling mount adaptors.

LWB1 Product card



Front plate

Back plate

Safety Features

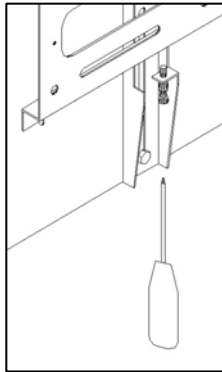

Dimensions

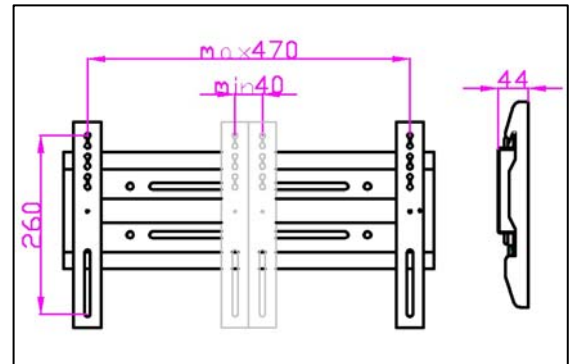

Technical data

Load capacity:	Up to 60 kg
Dimensions:	545x175x39mm
Max. / Min. Mounting interface (width x height):	470x260mm / 47x95xmm
Fits VESA standards:	75x75, 100x100, 200x100, 200x200, 400x200mm
Packaging dimensions:	570x180x45mm
Net weight (gross):	2,7(3,1) kg

Order Code:	Available Colours:	Type of packaging:	EAN product code:
LWB1c-R	Black (RAL9005)	Retail	5908252960040
LWB1s-R	Silver (RAL9006)	Retail	5908252960057
LWB1c-B	Black (RAL9005)	Brown	5908252960194
LWB1s-B	Silver (RAL9006)	Brown	5908252960200

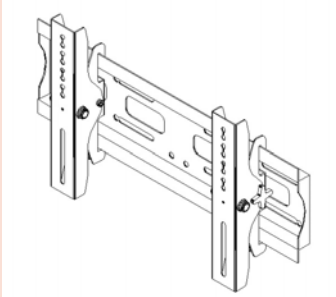

Overview

- *Universal Tilting Wall Mount for 22-32" plasma / LCD screens and a load capacity of up to 80kg*
- *Up to +/-15° adjustment of tilting angle for optimal viewing comfort*
- *Quick and easy installation*
- *Solid steel construction, powder coated*
- *Security screw holds the screen in exact position*
- *Back plate has several holes for mounting on brick, concrete and stud walls*
- *Fits VESA standards 75x75, 100x100x200x100x200x200 or 400x200 mm*
- *Packaging includes screws and spacers for different TV makes and models*
- *10 years warranty*

Similar products

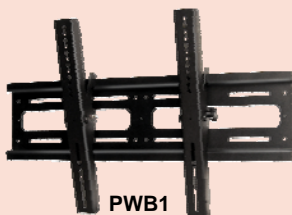

FOR HOME & OFFICE

LWB2

Universal Tilting Wall Mount for 22-32" plasma / LCD screens



LWB2 is an universal tilting wall mount for 22-32" plasma / LCD screens with a load capacity of up to 80kg. For optimal viewing comfort LWB2 allows up to +/-15° adjustment of tilt. Its design ensures quick, easy and safe installation:

LWB2 consists of a back plate that can be fixed to a brick, stud or concrete wall and the two front plates that are mounted to the back of the screen.

The screen together with the front plates can be comfortably hooked to the back plate. The universal bracket contains also two security screws in order to keep the screen in position.

Tilting angle can be comfortably adjusted by two handles at the side of the front plates.

After mounting screen hangs like a picture and distance to the wall is reduced to a minimum. Included in the box are screws and spacers for different TV makes and models.

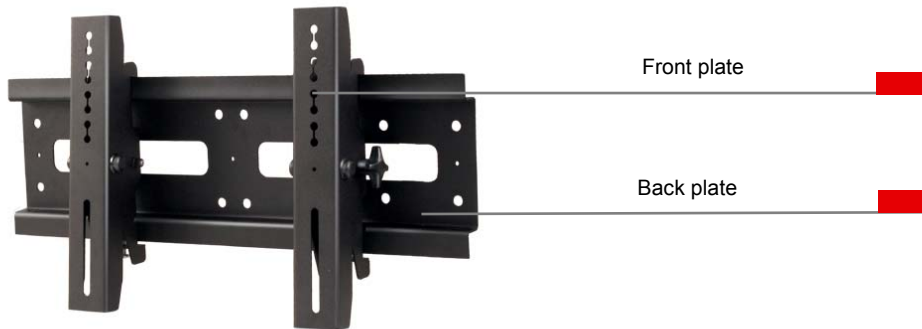

Range of Movement

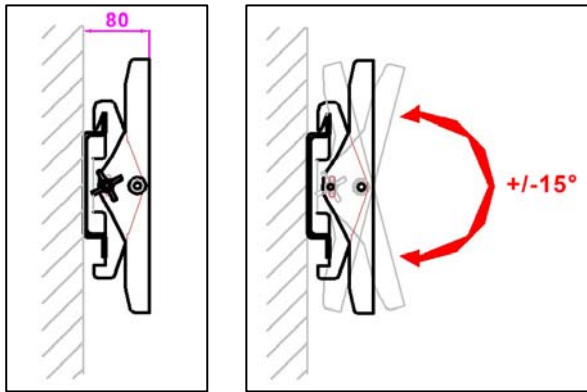

Dimensions

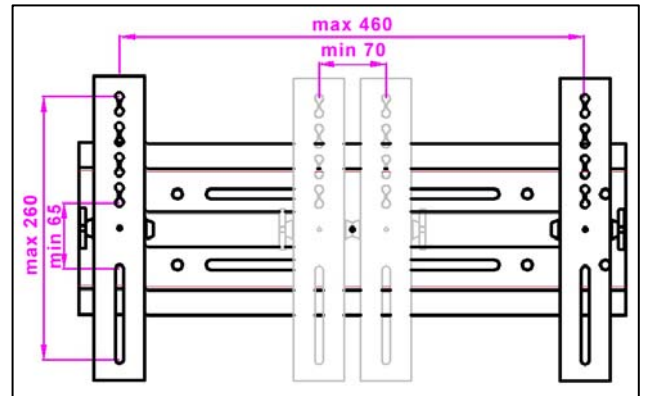

Technical data

Load capacity:	Up to 60 kg
Tilting Angle:	+/-15°
Dimensions:	550x185x45 mm
Max. / min. mounting interface (width x height):	460x260mm / 70x65mm
Fits VESA standards:	75x75, 100x100, 200x100, 200x200,400x200 mm
Packaging dimensions:	570x184x83mm
Net weight (gross):	2,5(2,9) kg

Order Code:	Available Colours:	Type of packaging:	EAN product code:
LWB2c-R	Black (RAL9005)	Retail	5908252960064
LWB2s-R	Silver (RAL9006)	Retail	5908252960071
LWB2c-B	Black (RAL9005)	Brown	5908252960217
LWB2s-B	Silver (RAL9006)	Brown	5908252960224

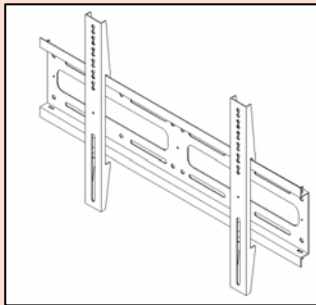

Overview

- *Universal Fixed Wall Mount for 32-60" plasma / LCD screens and a load capacity of up to 80kg*
- *Quick and easy installation*
- *Solid steel construction, powder coated*
- *Security screw holds the screen in position*
- *Back plate has several holes for mounting on brick, concrete and stud walls*
- *Fits VESA standards 100x100, 200x100, 200x200, 400x200, 400x400 or 600x400 mm*
- *Packaging includes screws and spacers for different TV makes and models*
- *After mounting, screen hangs like a picture and distance to the wall is reduced to a minimum*
- *10 years warranty*

Optional Adapters

- **SAP1**
- **CM1**
- **TR1 / TR2 / TR3**
- **SFP1**

FOR HOME & OFFICE

PWB1

Universal Fixed Wall Mount for 32-60" plasma / LCD screens

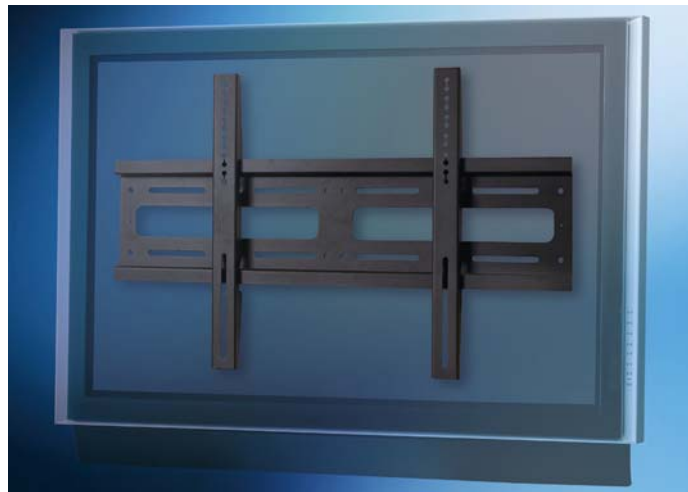

PWB1 is an universal fixed wall mount for 32-60" plasma / LCD screens with a load capacity of up to 80kg. Its design ensures quick, easy and safe installation*:

PWB1 consists of a back plate that can be fixed to a brick, stud or concrete wall and the two front plates which are mounted to the back of the screen.

The screen together with the front plates can be comfortably hooked to the back plate. The universal bracket contains also two security screws in order to keep the screen in position.

Included in the box are screws and spacers for different TV makes and models.

*PWB1 can be fixed directly to the wall or can be used with adaptors for swing arm, trolley or ceiling mount adaptors.

PWB1 Product card

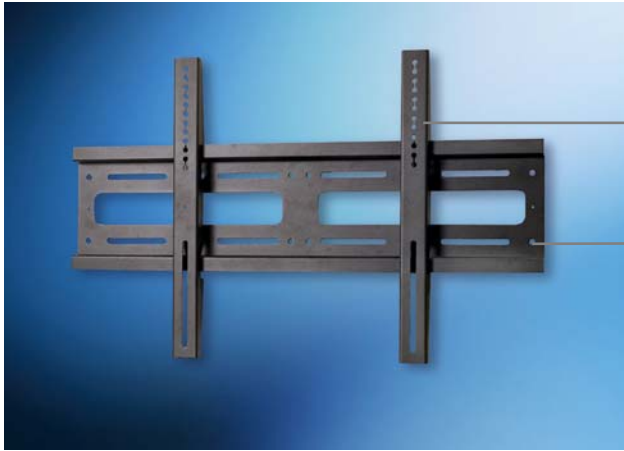

Front plate

Back plate

Safety Features

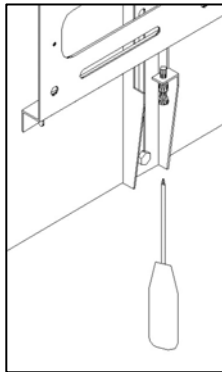

Dimensions

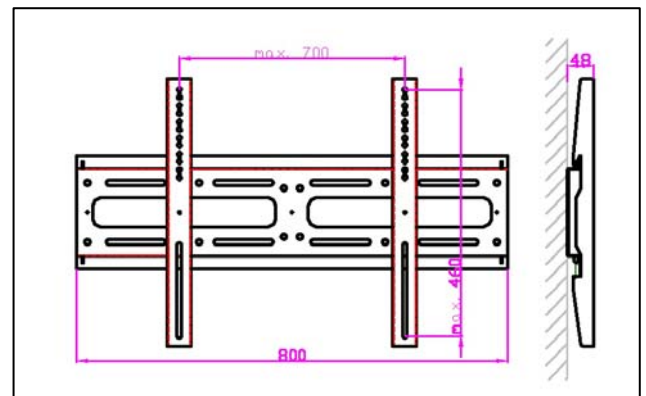

Technical data

Load capacity:	Up to 80 kg
Dimensions:	805x218x39 mm
Max. / min. mounting interface (width x height):	700x460 / 50x100mm
Fits VESA standards:	100x100, 200x100, 200x200, 400x200, 400x400 and 600x400 mm
Packaging dimensions:	830x220x45mm
Net weight (gross):	4,2 (4,7) kg

Order Code:	Available Colours:	Type of packaging:	EAN product code:
PWB1c-R	Black (RAL9005)	Retail	5908252960002
PWB1s-R	Silver (RAL9006)	Retail	5908252960019
PWB1c-B	Black (RAL9005)	Brown	5908252960156
PWB1s-B	Silver (RAL9006)	Brown	5908252960163

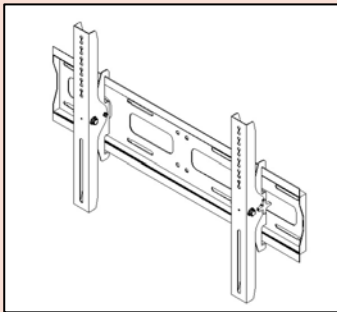

Overview

- *Universal Tilting Wall Mount for 32-60" plasma / LCD screens and a load capacity of up to 80kg*
- *Up to +/-15° adjustment of tilt for optimal viewing comfort*
- *Quick and easy installation*
- *Solid steel construction, powder coated*
- *Security screw holds the screen in position*
- *Back plate has several holes for mounting on brick, concrete and stud walls*
- *Fits VESA standards 100x100, 200x100x200x200, 400x200, 400x400 or 600x400 mm*
- *Packaging includes screws and spacers for different TV makes and models*
- *10 years warranty*

Similar products

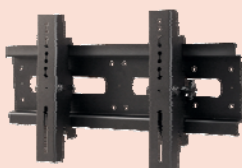

LWB2

FOR HOME & OFFICE

PWB2

Universal Tilting Wall Mount for 32-60" plasma / LCD screens



PWB2 is an universal tilting wall mount for 32-60" plasma / LCD screens with a load capacity of up to 80kg. For optimal viewing comfort PWB2 allows up to +/-15° adjustment of tilt. Its design ensures quick, easy and safe installation:

PWB2 consists of a back plate that can be fixed to a brick, stud or concrete wall and the two front plates that are mounted to the back of the screen.

The screen together with the front plates can be comfortably hooked to the back plate. The universal bracket contains also two security screws in order to keep the screen in position.

Tilting angle can be comfortably adjusted by two handles at the side of the front plates.

After mounting screen hangs like a picture and distance to the wall is reduced to a minimum. Included in the box are screws and spacers for different TV makes and models.

PWB2 Product card

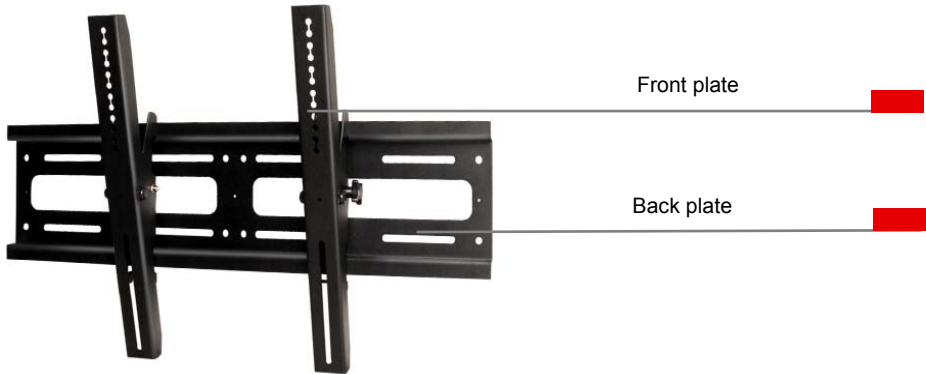

Range of Movement

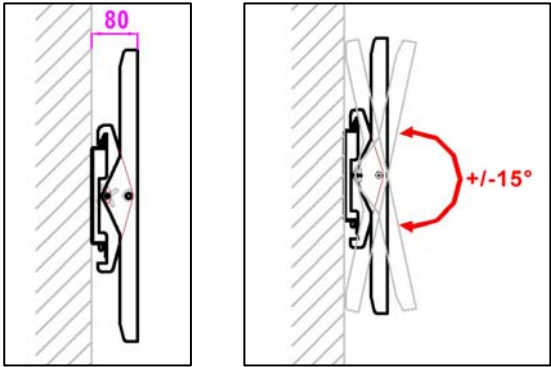

Dimensions

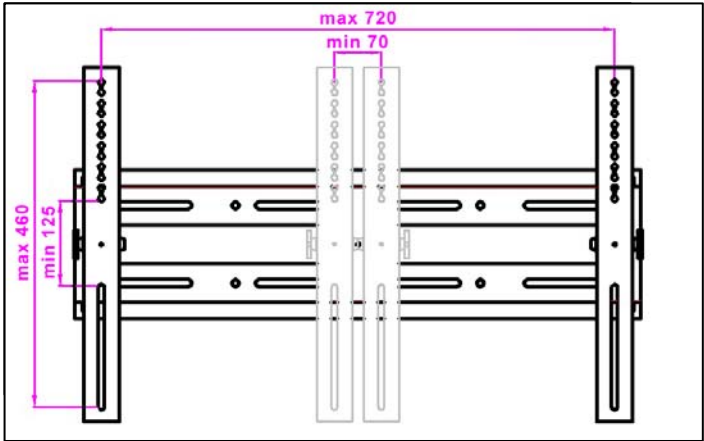

Technical data

Load capacity:	Up to 80 kg
Tilting Angle:	+/-15°
Dimensions:	805x218x39 mm
Max. / min. mounting interface (width x height):	720x460mm / 70x125mm
Fits VESA standards:	100x100, 200x100, 200x200, 400x200, 400x400 or 600x400 mm
Packaging dimensions :	830x225x80mm
Net weight (gross):	5,0 (5,5) kg

Order Code:	Available Colours:	Type of packaging:	EAN product code:
PWB2c-R	Black (RAL9005)	Retail	5908252960026
PWB2s-R	Silver (RAL9006)	Retail	5908252960033
PWB2c-B	Black (RAL9005)	Brown	5908252960170
PWB2s-B	Silver (RAL9006)	Brown	5908252960187

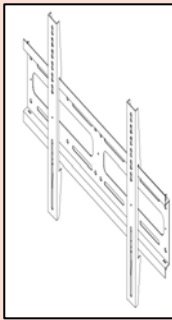

Overview

- *Universal Fixed Wall Mount for 32-60" plasma / LCD screens and a capacity load of up to 80kg*
- *Quick and easy installation*
- *Solid steel construction, powder coated*
- *Security screw holds the screen in position*
- *Back plate has several holes for mounting on brick, concrete and stud walls*
- *Fits VESA standards 100x100, 200x100, 200x200, 400x200, 400x400 or 600x400 mm*
- *Packaging includes screws and spacers for different TV makes and models*
- *After mounting, screen hangs like a picture for portrait viewing and distance to the wall is reduced to a minimum*
- *10 years warranty*

Optional Adapters

- **SAP1**
- **CM1**
- **TR1 / TR2 / TR3**
- **SFP1**

FOR HOME & OFFICE

PWB3

Universal Fixed Wall Mount for 32-60" plasma / LCD for vertical screen alignment



PWB3 is an universal fixed wall mount for 32-60" plasma / LCD screens for vertical alignment with a capacity load of up to 80kg. Its design ensures quick, easy and safe installation*:

PWB3 consists of a back plate that can be fixed to a brick, stud or concrete wall and the two front plates which are mounted to the back of the screen.

The screen together with the front plates can be comfortably hooked to the back plate. The universal bracket contains also two security screws in order to keep the screen in position.

Included in the box are screws and spacers for different TV makes and models.

The vertical alignment of the screen makes it suitable especially for professional applications where viewing in portrait mode is required.

*PWB3 can be fixed directly to the wall or can be used with adaptors for swing arm, trolley or ceiling mount adaptors.

PWB3 Product card

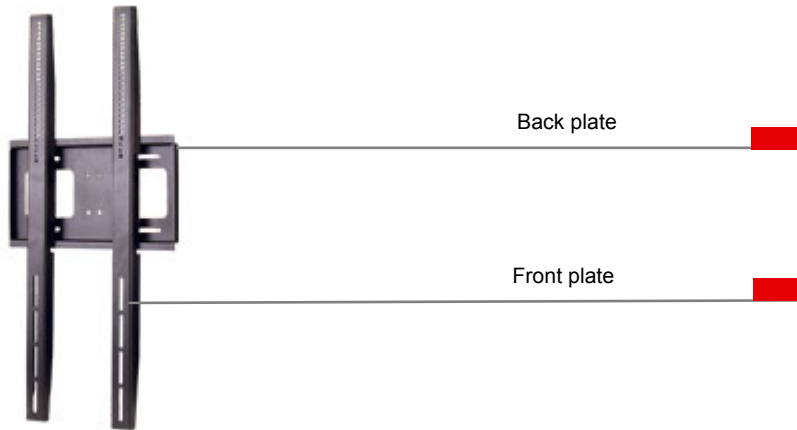

Safety Features

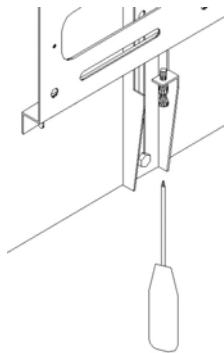

Dimensions

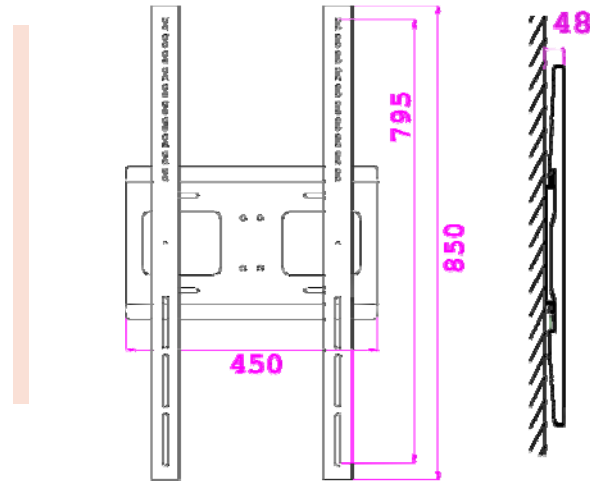

Technical data

Capacity load:	Up to 80 kg
Dimensions:	805x218x39 mm
Max. / min. mounting interface (width x height):	460x795 / 100x50mm
Fits VESA standards:	100x100, 200x100, 200x200, 400x200, 400x400 and 600x400 mm
Dimensions of packaging:	830x220x45mm
Net weight (gross):	4,2 (4,7) kg

Order Code:	Available Colours:	Type of packaging:	EAN product code:
PWB3c-B	Black (RAL9005)	Brown	5908252960910
PWB3s-B	Silver (RAL9006)	Brown	5908252960927

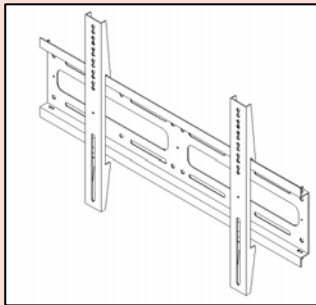

Overview

- *Universal Fixed Wall Mount for 37-60" plasma / LCD screens and a capacity load of up to 80kg*
- *Quick and easy installation*
- *Solid steel construction, powder coated*
- *Security screw holds the screen in position*
- *Back plate has several holes for mounting on brick, concrete and stud walls*
- *Fits VESA standards 100x100, 200x100, 200x200, 400x200, 400x400, 600x400, 800x200 and 800x400mm*
- *Packaging includes screws and spacers for different TV makes and models*
- *After mounting, screen hangs like a picture and distance to the wall is reduced to a minimum*
- *10 years warranty*

Optional Adapters

- **SAP1**
- **CM1**
- **TR1 / TR2 / TR3**
- **SFP1**

FOR HOME & OFFICE

TWB1

Universal Fixed Wall Mount for 37-60" plasma / LCD screens with large mounting interface



TWB1 is an universal fixed wall mount for 37-60" plasma / LCD screens with a capacity load of up to 80kg. Its design ensures quick, easy and safe installation*:

TWB1 consists of a back plate that can be fixed to a brick, stud or concrete wall and the two front plates which are mounted to the back of the screen.

The screen together with the front plates can be comfortably hooked to the back plate. The universal bracket contains also two security screws in order to keep the screen in position.

This universal bracket was especially designed to fit TV makes and models that require a large mounting interface (e.g. Philips).

Included in the box are screws and spacers for different TV makes and models.

*TWB1 can be fixed directly to the wall or can be used with adaptors for swing arm, trolley or ceiling mount adaptors.

TWB1 Product card



Safety Features

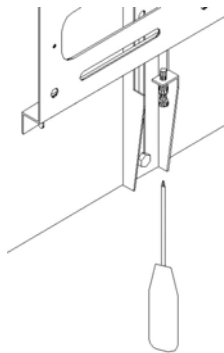

Dimensions

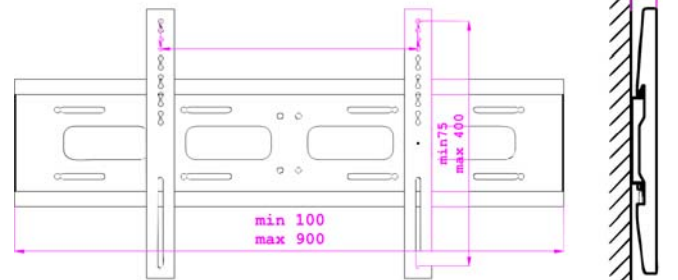

Technical data

Capacity load:	Up to 80 kg
Dimensions:	905x218x39 mm
Max. / min. mounting interface (width x height):	900x400 / 50x100mm
Fits VESA standards:	100x100, 200x100, 200x200, 400x200, 400x400, 600x400, 800x200, and 800x400 mm
Dimensions of packaging:	930x220x45mm
Net weight (gross):	5,2 (5,7) kg

Order Code:	Available Colours:	Type of packaging:	EAN product code:
TWB1c-B	Black (RAL9005)	Brown	5908252960859
TWB1s-B	Silver (RAL9006)	Brown	5908252960866

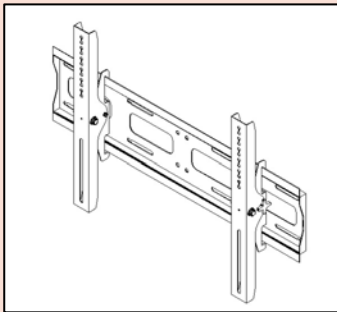

Overview

- *Universal Fixed Wall Mount for 37-60" plasma / LCD screens and a capacity load of up to 80kg*
- *Up to +/-15° adjustment of tilt for optimal viewing comfort*
- *Quick and easy installation*
- *Solid steel construction, powder coated*
- *Security screw holds the screen in position*
- *Back plate has several holes for mounting on brick, concrete and stud walls*
- *Fits VESA standards 100x100, 200x100, 200x200, 400x200, 400x400, 600x400, 800x200, and 800x400 mm*
- *Packaging includes screws and spacers for different TV makes and models*
- *10 years warranty*

Similar products

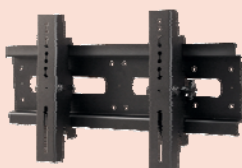

LWB2

FOR HOME & OFFICE

TWB2

Universal Tilting Wall Mount for 37-60" plasma / LCD screens



TWB2 is an universal fixed wall mount for 37-60" plasma / LCD screens with a capacity load of up to 80kg. For optimal viewing comfort TWB2 allows up to +/-15° adjustment of tilt. Its design ensures quick, easy and safe installation*:

TWB2 consists of a back plate that can be fixed to a brick, stud or concrete wall and the two front plates that are mounted to the back of the screen.

The screen together with the front plates can be comfortably hooked to the back plate. The universal bracket contains also two security screws in order to keep the screen in position.

Tilting angle can be comfortably adjusted by two handles at the side of the front plates.

This universal bracket was especially designed to fit TV makes and models that require a large mounting interface (e.g. Philips).

After mounting screen hangs like a picture and distance to the wall is reduced to a minimum. Included in the box are screws and spacers for different TV makes and models.

*TWB2 can be fixed directly to the wall or can be used with adaptors for swing arm, trolley or ceiling mount adaptors.

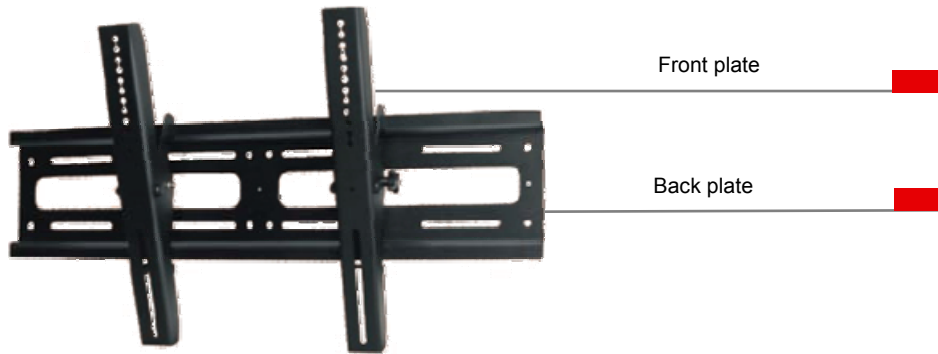

Range of Movement

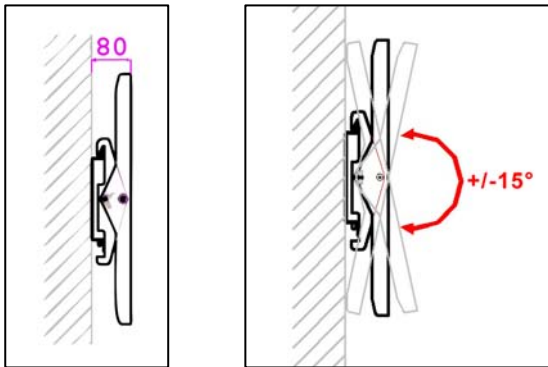

Dimensions

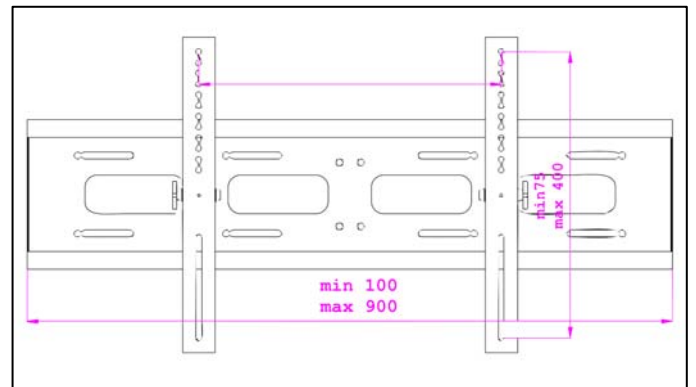

Technical data

Capacity load:	Up to 80 kg
Tilting Angle:	+/-15°
Dimensions:	905x218x39 mm
Max. / min. mounting interface (width x height):	900x400mm / 75x100mm
Fits VESA standards:	100x100, 200x100, 200x200, 400x200, 400x400, 600x400, 800x200, and 800x400 mm
Dimensions of the box:	930x225x80mm
Net weight (gross):	6,0 (6,5) kg

Order Code:	Available Colours:	Type of packaging:	EAN product code:
TWB2c-B	Black (RAL9005)	Brown	5908252960873
TWB2s-B	Silver (RAL9006)	Brown	5908252960880

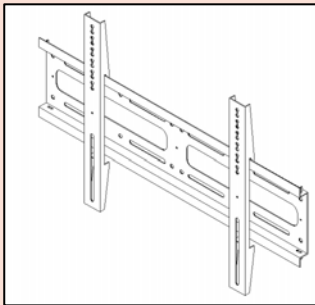

Overview

- *Universal Fixed Wall Mount for 60" and larger plasma / LCD screens and a capacity load of up to 110kg*
- *Quick and easy installation*
- *Solid steel construction, powder coated*
- *Security screw holds the screen in position*
- *Back plate has several holes for mounting on brick, concrete and stud walls*
- *Fits VESA standards 100x100, 200x100, 200x200, 400x200, 400x400, 600x400, 800x200 and 800x400mm*
- *Packaging includes screws and spacers for different TV makes and models*
- *After mounting, screen hangs like a picture and distance to the wall is reduced to a minimum*
- *10 years warranty*

Optional Adapters

- **SAP1**
- **CM1**
- **TR1 / TR2 / TR3**
- **SFP1**

XWB1

Universal Fixed Wall Mount for 60" and larger plasma / LCD screens with large mounting interface



XWB1 is an universal fixed wall mount for 60" and larger plasma / LCD screens with a capacity load of up to 110 kg. Its design ensures quick, easy and safe installation*:

XWB1 consists of a back plate that can be fixed to a brick, stud or concrete wall and the two front plates which are mounted to the back of the screen.

The screen together with the front plates can be comfortably hooked to the back plate. The universal bracket contains also two security screws in order to keep the screen in position.

This universal bracket was especially designed to fit TV makes and models that require a large mounting interface and a heavy duty capacity load.

Included in the box are screws and spacers for different TV makes and models.

*XWB1 can be fixed directly to the wall or can be used with adaptors for swing arm, trolley or ceiling mount adaptors.

XWB1 Product card



Safety Features

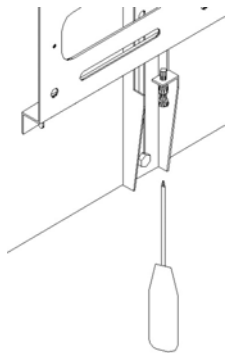

Dimensions

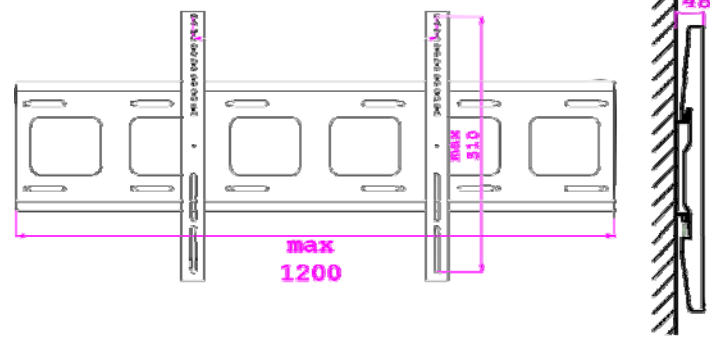

Technical data

Capacity load:	Up to 110 kg
Dimensions:	1205x518x39 mm
Max. / min. mounting interface (width x height):	900x400 / 50x100mm
Screen size:	Over 60"
Max. distance to wall:	48mm
Dimensions of packaging:	1230x220x45mm
Net weight (gross):	5,2 (5,7) kg

Order Code:	Available Colours:	Type of packaging:	EAN product code:
XWB1c-B	Black (RAL9005)	Brown	5908252960897
XWB1s-B	Silver (RAL9006)	Brown	5908252960903

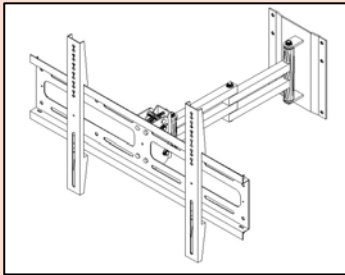

Overview

- Suitable for almost all screens between 32" and 60" screen size
- Maximum load capacity up to 80kg with PWB1 or TWB1.
- Easy and quick installation with PWB1 or TWB1
- Adjust the viewing angle directly at the adapter for a comfortable viewing position
- Large range of motion provided by three swivel points
- Solid back plate
- Solid steel construction with a stainless and powder coated steel
- 10 years warranty

Optional components

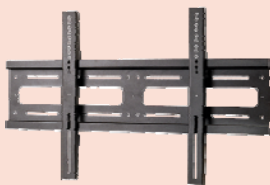

PWB1
Universal mount for 32-60" screens

SAP1

Dual Swing Arm Wall Mount for 32-60" Plasma/LCD screens (adaptor for PWB1/TWB1)



The dual swing arm wall mount adaptor SAP1 for 32-60" plasma / LCD displays offers ultimate flexibility and optimal adjustment possibilities for your screen*.

It can be easily extended, tilted, turned and swiveled to set the plasma / LCD display into the most desirable position or retract it to the wall when it is not needed.

The solid construction with a heavy wall plate and an additional supporting plate at the adapter holds up to 80kg.

It finds applications in places where flexible viewing solution is needed including:

Applications:

- conference rooms
- schools
- offices
- laboratories and hospitals
- homes

* The product can be ordered in combination with universal adapter PWB1 or TWB1.

FOR HOME & OFFICE



Wall plate

Universal mount PWB1

Range of movement

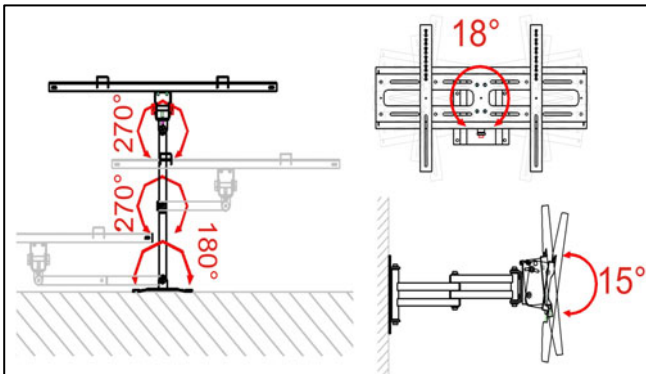

Dimensions

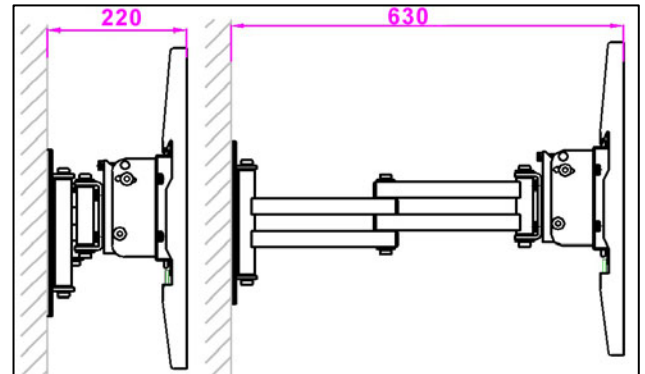

Technical data

Maximum load capacity:	Up to 80kg with PWB1
Tilt:	15°
Swivel:	180° - 270°
Turn:	18°
Max. / min. distance to the wall:	630mm / 220mm
Additional supporting plate:	yes
Dimensions of the back plate:	200x250mm
Packaging dimensions:	670x270x95mm
Net weight (gross):	6,3 (6,8) kg

Order Code:	Available Colours:	Type of packaging:	EAN product code:
SAP1c-B	Black (RAL9005)	Brown	5908252960088
SAP1s-B	Silver (RAL9006)	Brown	5908252960095

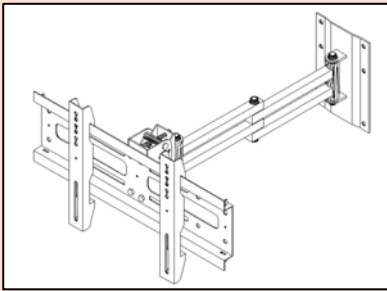

Overview

- Suitable for almost all screens between 22-32" screen size
- Maximum load capacity up to 60kg with LWB1
- Easy and quick installation with LWB1
- Adjust the viewing angle directly at the adapter for a comfortable viewing position
- Large range of motion provided by three swivel points
- Solid powder coated steel construction
- 10 years warranty

Optional components

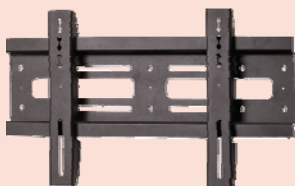

LWB1
Adapter for 22-32" screens

SAL1

Dual Swing Arm Wall Mount for 22-32" Plasma/LCD screens (adaptor for LWB1)



The dual swing arm wall mount adaptor SAL1 for 22-32" plasma / LCD displays offers ultimate flexibility and optimal adjustment possibilities for your screen*.

The SAL1 adapter can be easily extended, tilted, turned and swiveled to set the plasma / LCD display into the most desirable position. It can be retracted to the wall when extension is not needed.

The solid construction with a heavy wall plate and an additional supporting plate at the adapter carries a load capacity of up to 60kg.

It finds applications in places where flexible viewing solution is needed including:

Applications:

- conference rooms
- schools
- offices
- laboratories and hospitals
- homes

* The product can be ordered in combination with universal

FOR HOME & OFFICE

SAL1 Product card

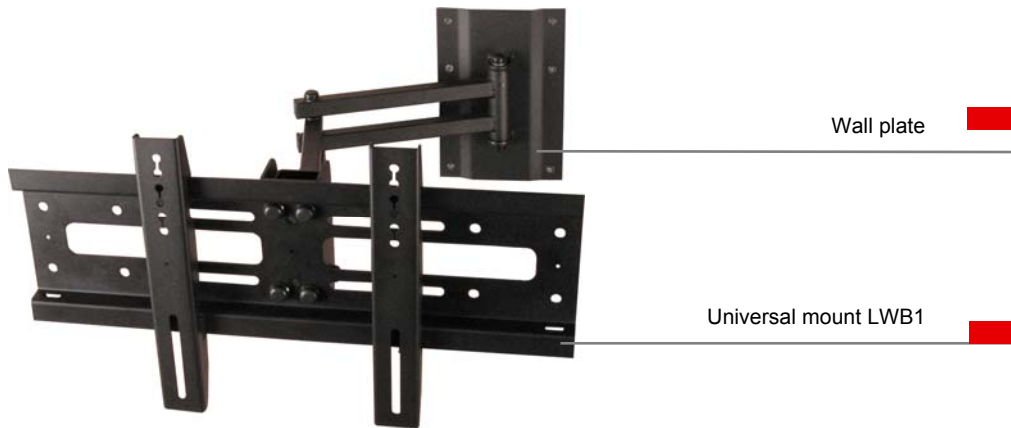

Range of movement

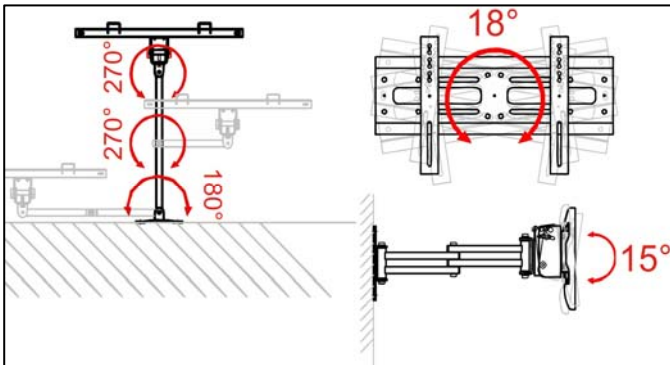

Dimensions

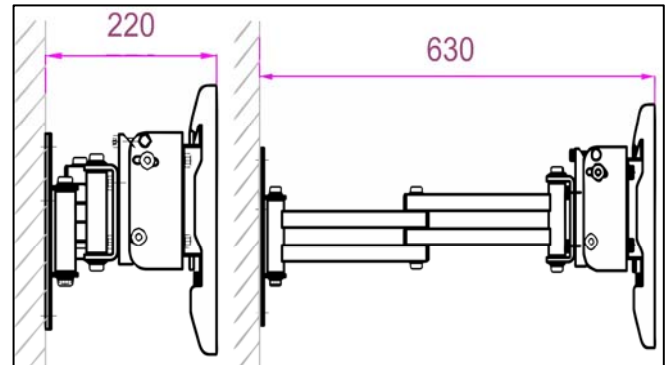

Technical data

Maximum load capacity:	Up to 60kg with LWB1
Tilt:	15°
Swivel:	180° - 270°
Turn:	18°
Max. / min. distance to the wall:	220mm / 630mm
Dimensions of the back plate:	150x220mm
Packaging dimensions:	670x270x95mm
Net weight (gross):	4,0 (4,4) kg

Order Code:	Available Colours:	Type of packaging:	EAN product code:
SAL1c-B	Black (RAL9005)	Brown	5908252960231
SAL1s-B	Silver (RAL9006)	Brown	5908252960248

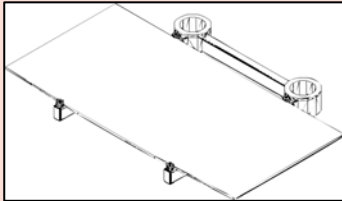

Overview

- *Elegant accessory for DVD players, VCRs and Laptops*
- *Maximum load capacity up to 10kg*
- *Easy and quick installation with TR1, TR2 and TR3*
- *Height adjustable*
- *Security glass for safe installation*
- *Solid stainless steel construction with powder coated parts*

Accessory for:

- **TR1**
Plasma / LCD Trolley for 22-60" screens
- **TR2**
Plasma / LCD Trolley for 22-60" screens
- **TR3**
Dual Plasma / LCD Trolley for 22-60" screens

FOR HOME & OFFICE

TRS1

Adjustable glass shelf (optional component for TR1 and TR2)



The glass shelf TRS1 is an elegant solution to provide storage space for DVD players, VCRs and Laptops.

It can be attached to the Trolleys TR1, and TR2. The glass shelf comes with dimmed security glass and a solid frame to provide safe installation with the trolley.

TRS1 is smooth height adjustable by two allen screws on the back of the shelf.

The cables of devices can be hidden in the wholes of the poles of the trolleys.

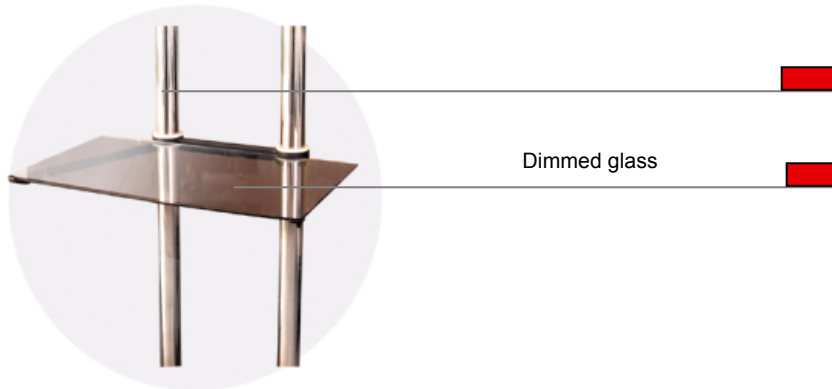

Dimensions

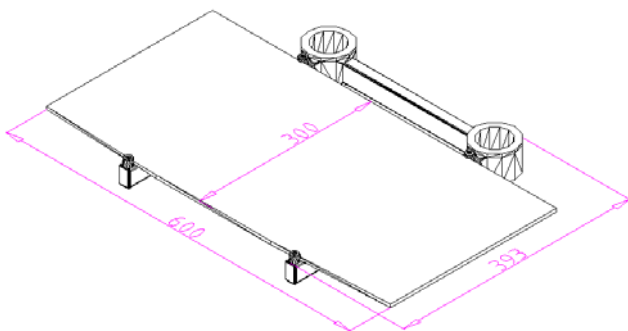

Other products



**Adjustable glass
shelve TRS2**

Technical data

Maximum load capacity:	Up to 10kg
Dimensions:	600x300mm
Net weight (gross):	3,4 (3,8) kg

Order Code:	Available Colours:	Type of packaging:	EAN product code:
TRS1c-B	Black (RAL9005)	Brown	5908252960835
TRS1s-B	Silver (RAL9006)	Brown	5908252960842



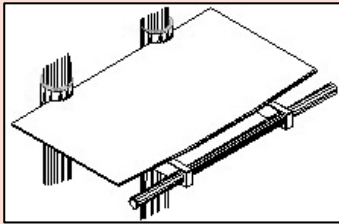

Overview

- *Elegant accessory for DVD players, VCRs and Laptops*
- *Maximum load capacity up to 10kg*
- *Easy and quick installation with TR1, TR2 and TR3*
- *Height adjustable*
- *Comes with a handle for easy movement of the trolley*
- *Solid stainless steel construction with powder coated parts*

Accessory for:

- **TR1**
Plasma / LCD Trolley for 22-60" screens
- **TR2**
Plasma / LCD Trolley for 22-60" screens
- **TR3**
Dual Plasma / LCD Trolley for 22-60" screens

FOR HOME & OFFICE

TRS2

**Adjustable glass shelf with handle
(optional component for TR1, TR2 and TR3)**



The glass shelf TRS2 is an elegant solution to provide storage space for DVD players, VCRs and Laptops.

It can be attached to the Trolleys TR1, TR2 and TR3. The dimmed glass shelf comes with a handle which allows easy and safe movement of the trolley.

TRS2 is smooth height adjustable by two allen screws on the back of the shelf.

The cables of devices can be hidden in the wholes of the poles of the trolleys.

TRS2 Product card

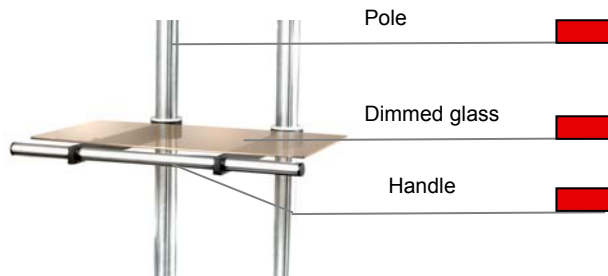

Shelf frame and cable management

Attached to TR2 and PWB1



Dimensions

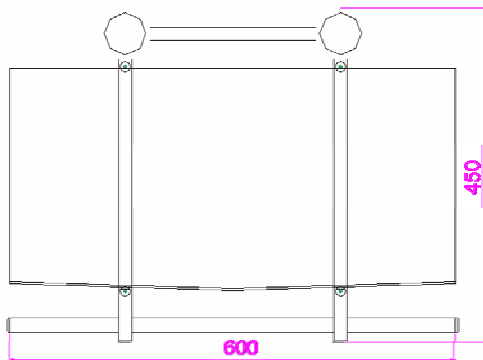

Other products



Adjustable glass shelf TRS1

Technical data

Maximum load capacity:	Up to 10kg
Dimensions:	600x450mm
Net weight (gross):	5,0 (8,0) kg

Order Code:	Available Colours:	Type of packaging:	EAN product code:
TRS2c-B	Black (RAL9005)	Brown	5908252960255
TRS2s-B	Silver (RAL9006)	Brown	5908252960262

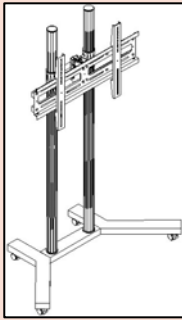

Overview

- Suitable for almost all screens between 22-60" screen size
- Maximum capacity load up to 80kg
- Easy and quick installation with PWB1, TWB1, LWB1 or GD23
- Adjust the viewing angle directly at the adapter for a comfortable viewing position
- Solution for Cable Management is provided
- Solid steel construction with stainless and powder coated steel
- 10 years warranty

Optional components

- **LWB1**
Adapter for 22-32" screens
- **PWB1**
Adapter for 32-60" screens
- **TWB1**
Adapter for 37-60" screens
- **GD23**
Adapter for VESA 75x75 & VESA 100x100 standard
- **TRS1**
Glass shelf
- **TRS2**
Glass shelf with handles

FOR HOME & OFFICE

TR1

Plasma / LCD Trolley for 22-60" screens (adaptor for PWB1/TWB1/LWB1)



The Trolley TR1 is the best mobile solution for data presentation in all kind of interiors (board room class and conference rooms). It can take up screens with a size of 22"-60" and a maximum capacity load of up to 80kg*. In order to increase stability TR1 comes with an additional backplane which provides even more stability and durability.

It finds applications in places where a mobile presentation solution is needed.

Applications:

- conference rooms
- schools
- offices
- laboratories and hospitals
- homes
- fairs

TR1 comes with wheels or with rubber feet as an option.

* The product can be ordered in combination with PWB1, TWB1, LWB1 or GD23 and the glass shelves TRS1 or TRS2.

TR1 Product card

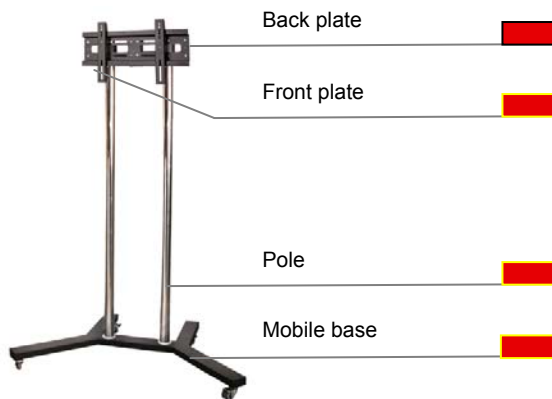

Optional glass
shelve TRS1

Assembled with PWB1



Range of movement

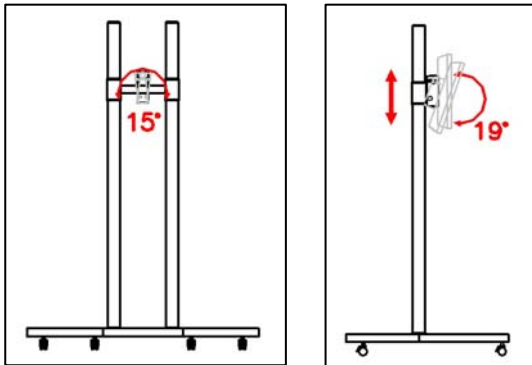

Dimensions

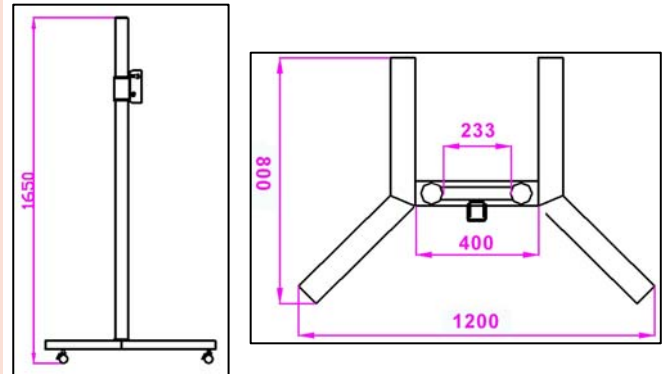

Technical data

Maximum capacity load:	Up to 60kg with LWB1 Up to 80kg with PWB1 Up to 15kg with GD23
Tilt:	19°
Swivel:	15°
Dimensions:	1200x1650x800mm
Dimensions of the box:	860x1620x180mm
Net weight (gross):	30 (33) kg
No. of units on one pallet:	7

Order Code:	Available Colours:	Type of packaging:	EAN product code:
TR1c-B	Black (RAL9005)	Brown	5908252960118
TR1s-B	Silver (RAL9006)	Brown	5908252960125

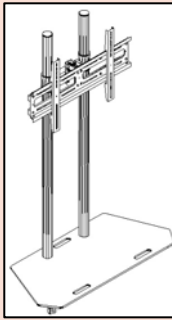

Overview

- Suitable for almost all screens between 22-60" screen size
- Maximum capacity load up to 80kg
- Easy and quick installation with TWB1, PWB1, LWB1 or GD23
- Adjust the viewing angle directly at the adapter for a comfortable viewing position
- Solution for Cable Management is provided
- Solid steel construction with stainless and powder coated steel
- 10 years warranty

Optional components

- **LWB1**
Adapter for 22-32" screens
- **TWB1**
Adapter for 37"-60" screens
- **PWB1**
Adapter for 32-60" screens
- **GD23**
Adapter for VESA 75x75 & VESA 100x100 standard
- **TRS1**
Glass shelf
- **TRS2**
Glass shelf with handles

FOR HOME & OFFICE

TR2

Plasma / LCD Trolley for 22-60" screens (adaptor for PWB1, TWB1 or LWB1)



TR2 is a new tiltable Plasma/LCD Trolley adapter for PWB1, TWB1 and LWB1 mounts. With its unique and shapely design it suits the need for professional presentations. Wheels and the optional glass shelf with integrated handles provide maximum mobility and flexibility to reach your target audience effortlessly. The Trolley TR2 is the best mobile solution for data presentation in all kind of interiors (board room class and conference rooms). It can take up screens with a size of 22"-60" and a maximum capacity load of up to 80kg*. In order to increase stability TR2 comes with an additional backplane which provides even more stability and durability.

It finds applications in places where a mobile presentation solution is needed.

Applications:

- conference rooms
- schools
- offices
- laboratories and hospitals
- homes
- fairs

* The product can be ordered in combination with TWB1, PWB1, LWB1 or GD23 and the glass shelves TRS1 or TRS2. TR2 comes with wheels or with rubber feet (order code: RF) as an option.

TR2 Product card

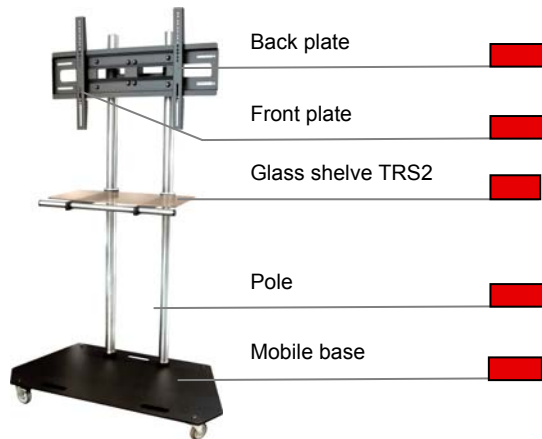

Optional glass
shelve TRS1

Assembled with PWB1



Range of movement

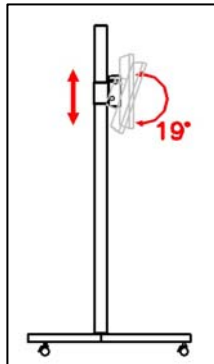
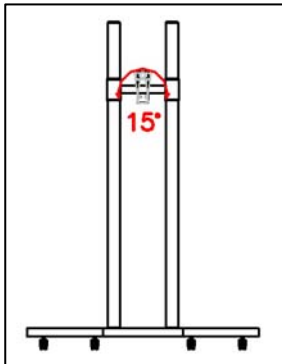

Dimensions

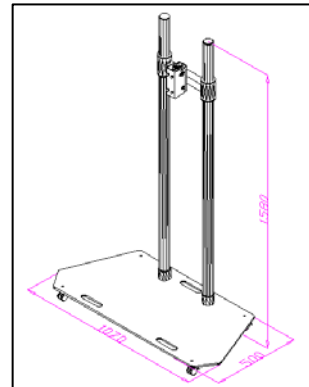

Technical data

Maximum capacity load:	Up to 60kg with LWB1 Up to 80kg with PWB1 Up to 15kg with GD23
Tilt:	19°
Swivel:	15°
Dimensions:	1070x1580x500mm
Packaging dimensions:	550x1560x120mm
Net weight (gross):	55 (60) kg
No. of units per one pallet:	15

Order Code:	Available Colours:	Type of packaging:	EAN product code:
TR2c-B	Black (RAL9005)	Brown	5908252960781
TR2s-B	Silver (RAL9006)	Brown	5908252960798
RF	-	Brown	5908252960804

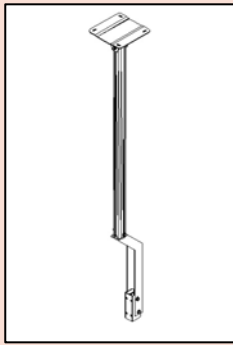

Overview

- Suitable for almost all screens between 22- 60" screen size
- Maximum load capacity up to 80kg
- Easy and quick installation with TWB1, PWB1 or LWB1
- Adjustment of viewing angle at the ceiling plate and directly at the mounting interface for most comfortable viewing position
- Solution for cable management is provided
- Solid steel construction with stainless and powder coated steel
- 10 years warranty

Other products



Wall mounts

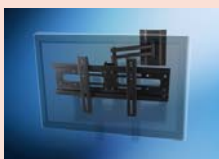

Swing arms

CM1

Ceiling mount for plasma / LCD screens with a screen size of 22"-60"

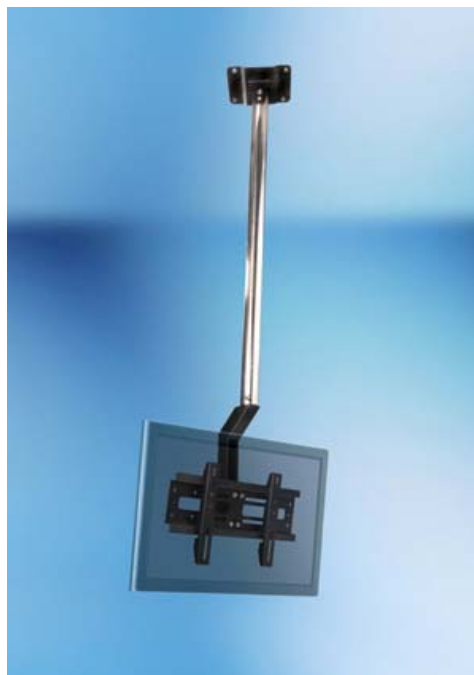

The ceiling mount CM1* is an attractive mounting solution for plasma / LCD screens with a screen size of 22"-60" and a maximum load capacity of up to 80kg. It finds applications especially in public places and places where only mounting to the ceiling is possible.

Applications:

- Public utility places (train stations, bus stations, airports, office, etc.)
- conference rooms
- schools
- offices
- laboratories and hospitals
- digital signage applications

* The product can be ordered in combination with TWB1, PWB1 or LWB1.

CM1 Product card



Pole
Mounting interface

Mounted with LWB1



Range of movement

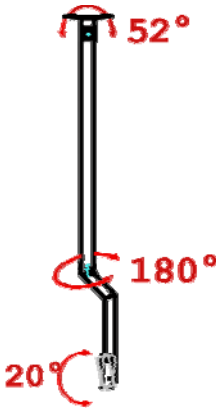

Technical data

Maximum capacity load:	80 kg
Total length:	1250mm
Pole length:	1000mm*
Tilt:	20°
Swivel:	180°
Packaging dimensions:	1270x310x150mm
Net weight (Gross):	6,5 (8,0) kg

**Other lengths available on request*

Dimensions

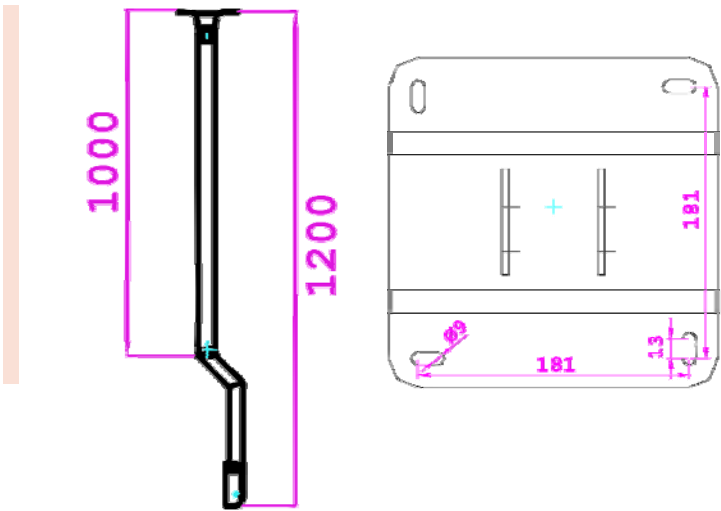

Order Code:	Available Colours:	Type of packaging:	EAN product code:
CM1c-B	Black (RAL9005)	Brown	5908252960132
CM1s-B	Silver (RAL9006)	Brown	5908252960149